

**LIMITED ONE YEAR WARRANTY(CST703-line;CST704-line)
LIMITED FIVE YEAR WARRANTY(CST713-line;CST714-line;CST723;CST724)**

1. TOTO warrants its products to be free from manufacturing defects under normal use and service for a period of one (1 or 5) year from the date of purchase. This warranty is extended only to the ORIGINAL PURCHASER.
2. TOTO's obligations under this warranty are limited to repair or replacement, at TOTO's option, of products or parts found to be defective, provided that such products were properly installed and used in accordance with this INSTRUCTION MANUAL. TOTO reserves the right to make such inspections as may be necessary in order to determine the cause of the defect. TOTO will not charge for labor or parts in connection with warranty repairs or replacements. TOTO is not responsible for the cost of removal, return and/or reinstallation of products.
3. This warranty does not apply to the following items:
 - a) Damage or loss sustained in a natural calamity such as fire, earthquake, flood, thunder, electrical storm, etc.
 - b) Damage or loss resulting from any unreasonable use, misuse, abuse, negligence, or improper maintenance of the product.
 - c) Damage or loss resulting from removal, improper repair, or modification of the product.
 - d) Damage or loss resulting from sediments or foreign matter contained in a water system.
 - e) Damage or loss resulting from improper installation or from installation of a unit in a harsh and/or hazardous environment.
4. This warranty gives you specific legal rights. You may have other rights which vary from state to state.
5. To obtain warranty repair service under this warranty, you must take the product or deliver it prepaid to a TOTO service facility together with a letter stating the problem, or contact a TOTO distributor or products service contractor, or write directly to TOTO U.S.A., INC., 1155 Southern Road, Morrow, GA 30260 (770) 282-8686 Fax: (770) 282-8701. If, because of the size of the product or nature of the defect, the product cannot be returned to TOTO, receipt by TOTO of written notice of the defect shall constitute delivery. In such case, TOTO may choose to repair the product at the purchaser's location or pay to transport the product to a service facility.

THIS WRITTEN WARRANTY IS THE ONLY WARRANTY MADE BY TOTO, REPAIR OR REPLACEMENT AS PROVIDED UNDER THIS WARRANTY SHALL BE THE EXCLUSIVE REMEDY AVAILABLE TO THE PURCHASER. TOTO SHALL NOT BE RESPONSIBLE FOR LOSS OF USE OF THE PRODUCT OR FOR OTHER INCIDENTAL, SPECIAL OR CONSEQUENTIAL DAMAGES OR EXPENSES INCURRED BY PURCHASER, OR FOR LABOR OR OTHER COSTS DUE TO INSTALLATION OR REMOVAL, OR COSTS OF REPAIRS BY OTHERS, OR FOR ANY OTHER EXPENSE NOT SPECIFICALLY STATED ABOVE EXCEPT TO THE EXTENT PROHIBITED BY APPLICABLE LAW, ANY IMPLIED WARRANTIES, INCLUDING THAT OF MERCHANTABILITY OR FITNESS FOR USE, ARE EXPRESSLY LIMITED TO THE DURATION OF THIS WARRANTY. SOME STATES DO NOT ALLOW LIMITATIONS ON HOW LONG AN IMPLIED WARRANTY LASTS, OR THE EXCLUSION OR LIMITATION OF INCIDENTAL OR CONSEQUENTIAL DAMAGES, SO THE ABOVE LIMITATION AND EXCLUSION MAY NOT APPLY TO YOU.

WARNING!!

TOTO shall not be responsible or liable for any failure of, or damage to, this plumbing product or product component caused by either chloramines in the treatment of public water supply or in-tank bowl cleaners containing chlorine (*calcium hypochlorite*)

Note: The use of high concentration of chlorine or chlorine related products can seriously damage the fittings. This damage can cause leakage and property damage.

TOTO U.S.A., INC. • 1155 Southern Road, Morrow, GA 30260
Tel. (770) 282-8686 • Fax. (770) 282-8701
www.totousa.com
Printed in U.S.A.

TOTO[®]
Perfection by Design

REV 03/01
0GU004Z

INSTALLATION INSTRUCTIONS For 1.6GPF Toilets:



- CST 703 - line
- CST 713 - line
- CST 704 - line
- CST 714 - line
- CST 723
- CST 724

IMPORTANT

Read these instructions thoroughly before beginning work.

You have purchased one of the best working toilets available today, backed by TOTO's worldwide finest reputation.

Please leave instructions for customers. These instructions contain maintenance information.

COMMON TOOLS NEEDED:

- 12" pipe wrench
- 10" adjustable wrench
- Carpenter's level
- Tape measure
- Plier
- Screwdriver
- Putty knife

MATERIALS REQUIRED:

- Supply tube / connector
- Supply stop
- Mounting bolts (2)
- Wax ring / seal

TOTO[®]
Perfection by Design

Step 1
PIPING CHECK AND ROUGH-IN

In order for your new TOTO Toilet to fit correctly, check the following dimensions (refer to rough-in drawings below). Distance from finished wall to the center of the rear toilet bolt must be as shown below in column A for the appropriate model.

MODEL NO.	A	B	C	D
CST703.14	14"	28-3/4"	14-5/8"	29-1/8"
CST704.14	14"	30-3/4"	14-5/8"	29-1/8"
CST703/713	12"	27"	14-5/8"	28-3/8"
CST703/713.10	10"	27"	14-5/8"	28-3/8"
CST704/714	12"	29"	14-5/8"	28-3/8"
CST704/714.10	10"	29"	14-5/8"	28-3/8"
CST704L/714 L	12"	29"	16-1/2"	30-3/8"
CST723	12"	27"	14-5/8"	32"
CST724	12"	29"	14-5/8"	32"

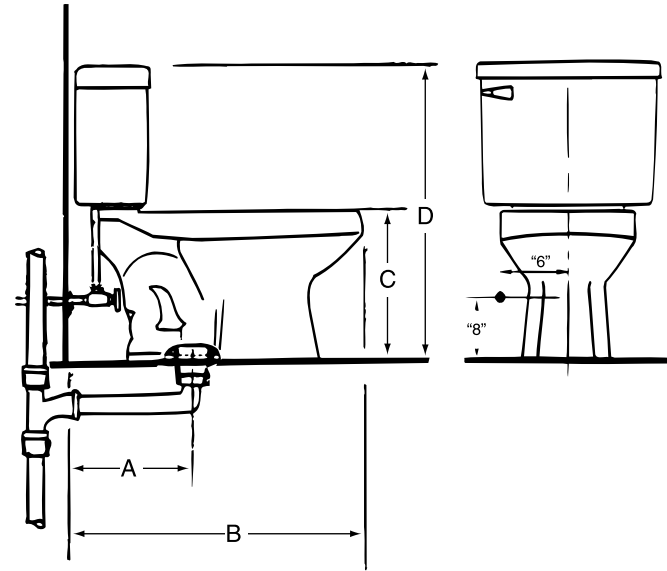

Step 2
INSTALLING TOILET MOUNTING BOLTS

Clean any construction debris out of the flange, then install the mounting bolts into the side slots of the floor flange. The bolts should be inserted into the slots, bolt heads down, threaded shank pointing upward.

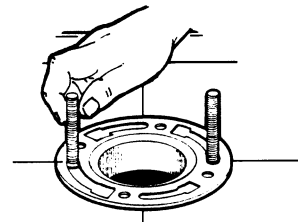

Step 3
BOWL INSTALLATION

Carefully turn the bowl upside down to insert a new wax gasket in the circular recess around the outlet opening.

Turn the bowl upright and gently lower it into position over closet bolts. Align the bowl. With the bowl properly aligned, press down firmly on both sides to set wax gasket.

CAUTION: Do not move the bowl after the wax gasket is set.

Thread nuts onto bolts and hand tighten. Alternately tighten bolts evenly until bowl is snug to flange. Install the bolt caps over bolts.

CAUTION: Do not over-tighten the nuts, damage to china may result.

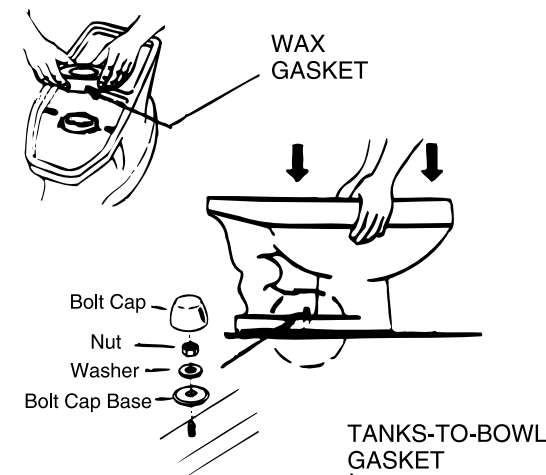

Step 4
TANK TO BOWL MOUNTING

Make sure the large tank-to-bowl gasket is mounted over flush valve outlet on underside of tank with bevel side down.

Make sure ballcock nut and flush valve nut are tightened properly. Pick up tank and carefully guide flush valve outlet into bowl inlet on bowl tank shelf.

Place washers on mounting bolts. Support tank and align mounting bolts through 1/2" holes in tank base and bowl mount shelf. Thread on nuts end, hand tighten before releasing the tank. Tighten nuts evenly until both sides do not rattle and tank sets snugly on bowl.

CAUTION: Do not over-tighten the nuts, damage to china may result.

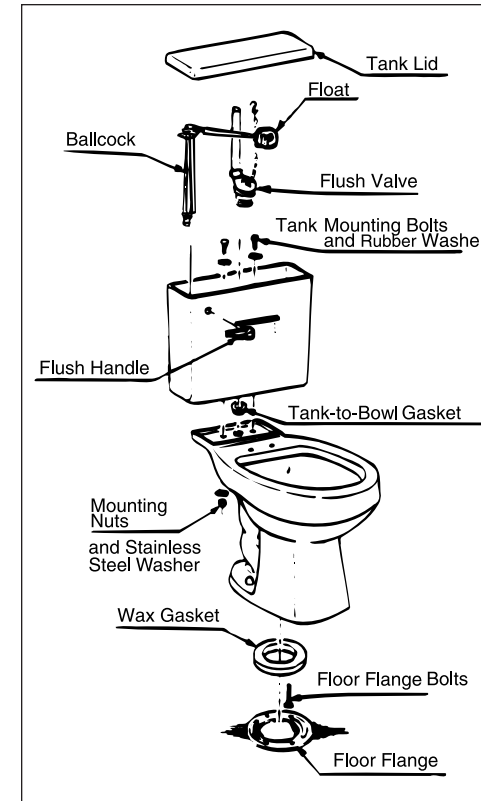
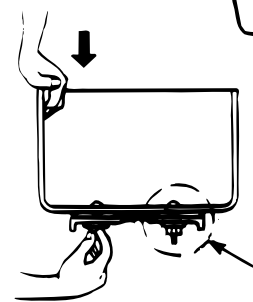

Step 5 **CONNECT FLAPPER VALVE CHAIN**

Connect hook on end of flapper valve chain to the middle hole of the plastic flush handle rod.

Step 6 **WATER LINE CONNECTION**

Flush water line briefly to ensure removal of debris. Determine the type of water supply pipe or tubing you have and note assembly parts you will use from the following:

With normal type connection, use cone washer, bevel side up, and compound nut to connect water line to ballcock inlet.

With flange type connection use a flat washer.

DO NOT OVER TIGHTEN NUT.

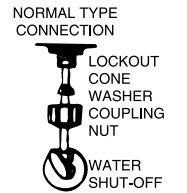

Step 7 **TESTING AND OPERATION**

Turn on water and fill tank.

Adjust ballcock so that water level in tank is at the water level mark.

Check for leaks. Tighten nuts slightly if necessary.

Flush tank several times. Check flapper valve for proper operation.

If handle is difficult to operate, make sure chain is not tangled.

Ballcock Adjustment:

- Make final water level adjustment using screws located on top of the ballcock
- Do not bent metal rod

ADJUSTMENT SCREW

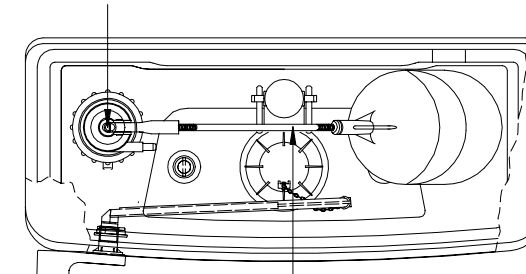

Step 8
Install the toilet tank lid, making sure it fits snugly.

Step 9
Install toilet seat.

ADJUSTMENT SCREW

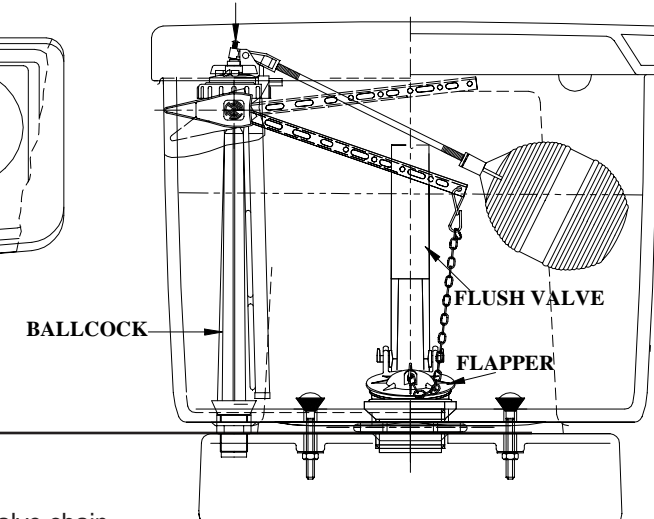

TROUBLE SHOOTING GUIDE

PROBLEM

1. Water does not shut off.
2. Poor flush.
3. Leaking

CAUSE/CORRECTION

- a. Check for proper slack in flapper valve chain.
- b. Water level in the tank was set too high.
- a. Water level too low. Adjust ballcock.
- b. Flapper closes too soon due to high pressure. Adjust ballcock flow rate.
- c. Trapway or drain line clogged. Plunge bowl or anger trap/drain to clear blockage.
- d. Check for proper slack in flapper valve chain.
- a. Tighten ballcock unit, large flush valve nut, mounting bolt nuts and water connection.

REPLACEMENT PARTS

Model	Flapper	Flush Valve	Ballcock	Trip Lever
CST723/724	THU112-2	THU106N	TSU14A	THU084#XX
CST714/714.10/714L/713/713.10	THU112	THU100N(-1)	TSU14A	THU061#XX
CST704/704.10/704L/703/703.10	THU112	THU100N-1	TSU14A	THU047#XX
CST704.14/CST704L.14/CST703.14	THU112	THU100N-1	TSU13A	THU004#XX

To order replacement parts please call 1-888-295-8134

#XX:Color/Finish code